



MANUAL

BAFANG E-SYSTEM



INHALT

Display DP C11.CAN.....	3
Display DP C240.CAN.....	21
Motor H300 (RM G010.250.D).....	37
Motor H400B (RM G020.250/350.DC).....	41
Motor H600 (RM G370.250.DC).....	45

DP C11.CAN



CONTENT

1.1 Important Notice	4	1.6.3 Selection mode.....	7
1.2 Introduction of Display	4	1.6.4 Headlights / backlighting.....	8
1.3 Product Description	5	1.6.5 Walk Assistance.....	8
1.3.1 Specifications.....	5	1.6.6 Service.....	9
1.3.2 Functions Overview.....	5	1.6.7 Battery capacity indication.....	9
1.4 Display	6	1.7 Settings	10
1.5 Key Definition	6	1.7.1 "Display Setting".....	10
1.6 Normal Operation	7	1.7.2 "Information".....	13
1.6.1 Switching the System On/Off.....	7	1.8 Error Code Definition	16
1.6.2 Selection of Support Levels.....	7		

1.1 IMPORTANT NOTICE

- If the error information from the display cannot be corrected according to the instructions, please contact your retailer.
- The product is designed to be waterproof. It is highly recommended to avoid submerging the display under water.
- Do not clean the display with a steam jet, high-pressure cleaner or water hose.
- Please use this product with care.
- Do not use thinners or other solvents to clean the display. Such substances can damage the surfaces.
- Warranty is not included due to wear and normal use and aging.

1.2 INTRODUCTION OF DISPLAY

- Model: DP C11.CAN BUS
- The housing material is PC and Acrylic, and the button material is made of silicone.



- The label marking is as follows:



Note: Please keep the QR code label attached to the display cable. The information from the Label is used for a later possible software update.

1.3 PRODUCT DESCRIPTION

1.3.1 Specifications

- Operating temperature: -20 °C~45 °C
- Storage temperature: -20 °C~50 °C
- Waterproof: IP65
- Storage room Humidity: 30%-70% RH

1.3.2 Functional Overview

- Speed display (including top speed and average speed, switching between km and miles)
- Battery capacity indicator
- Lighting control
- Brightness setting for backlight
- Walk assistance
- Indication of performance support
- Motor output power indicator
- Time display for single journeys
- Kilometer stand (including single-trip distance, total distance and remaining distance)
- Setting the support levels
- Energy consumption indicator CALORIES (Note: If the display has this function)
- Display for the remaining distance (Depends on your riding style)
- Information View (battery, controller, HMI and sensor)
- Error messages view

1.4 DISPLAY

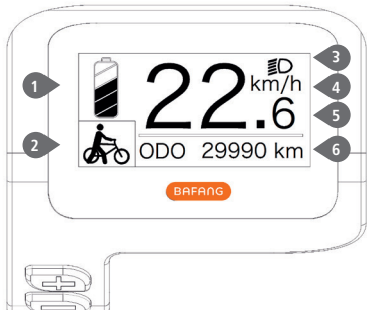

- 1 Display of battery capacity in real time.
- 2 Support level
- 3 The display shows this symbol , When the lights are turned on.
- 4 Unit of speed
- 5 Digital speed display
- 6 Trip: Daily kilometers (TRIP) - Total kilometers (ODO) - Top speed (MAX) - Average speed (AVG) - Remaining distance (RANGE) - Energy Consumption (CALORIES) - Output power (POWER)- Travel time (TIME).

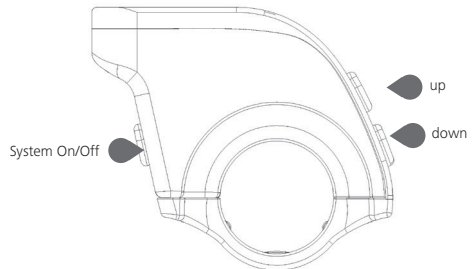
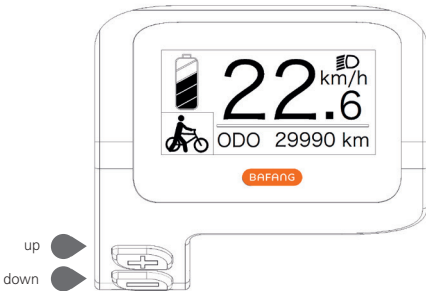

Service: Please see the service section

1.5 KEY DEFINITION



1.6 NORMAL OPERATION



1.6.1 Switching the System ON/OFF

Press and hold  (>2S) on the display to turn on the system. Press and hold  (>2S) again to turn off the system.

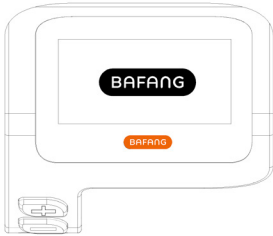
If the "automatic shutdown time" is set to 5 minutes (it can be reset with the "Auto Off" function, See "**Auto Off**"), the display will automatically be turned off within the desired time when it is not in operation. If the password function is enabled, you must enter the correct password to use the system.



1.6.2 Selection of Support Levels

When the display is turned on, press the  or  button (<0.5S) to switch to the support level, the lowest level is 0, the highest level is 5. When the system is switched on, the support level starts in level 1. There is no support at level 0.

For different assist levels please see part "**Assist Mode**".



1.6.3 Selection mode

Briefly press the  button (<0.5s) to see the different trip modes.

Trip: daily kilometers (TRIP) - total kilometers (ODO) - Maximum speed (MAX) - Average speed (AVG)
 - Remaining distance (RANGE) - Energy consumption (CALORIES) - Output power (POWER) - Travel time (TIME).

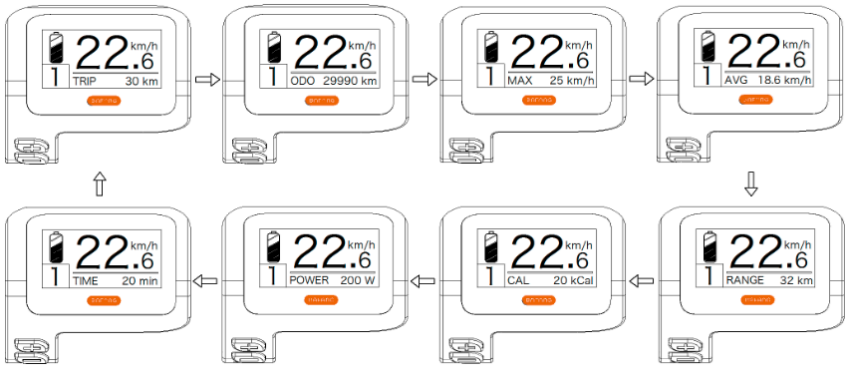

1.6.4 Headlights / backlighting

Hold the button (>2S) to activate the headlight and taillights.

Hold the button (>2S) again to turn off the headlight. The brightness of the backlight can be set in the display settings "**Brightness**".

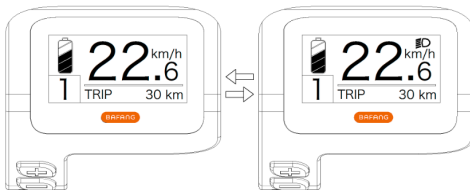

1.6.5 Walk Assistance

The Walk assistance can only be activated with a standing pedelec.

Activation: Press the button until this symbol appears. Next press and hold down the button whilst the is displayed, now the Walk assistance will activate. The symbol will blink and the pedelec moves approx. 5 km/h. After releasing the button, the motor stops automatically and switches back to level 0.

The Walk assistance can only be activated with a standing pedelec.



1.6.6 Service

The display shows "SERVICE" as soon as a certain number of kilometers or battery charges has been reached. With a mileage of more than 5000 km (or 100 charge cycles), the "SERVICE" function is displayed on the display. Every 5000 km the display "SERVICE" is displayed every time. This function can be set in the display settings.

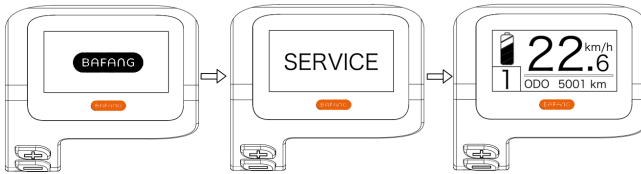

1.6.7 Battery capacity indicator

The battery capacity is shown in the top left of the display. Each full bar represents a remaining capacity of the battery in a percentage.

(as shown in the diagram below):

Capacity Range	Indicator
80%-100%	
60%-80%	
40%-60%	
20%-40%	
5%-20%	
<5%	blinking

1.7 SETTINGS

After the display is turned on, press and hold the **+** and **-** buttons (at the same time) to enter into the setting menu. By pressing the **+** or **-** button (<0.5S), you can highlight and select Display Setting, Information or Exit. Then press the **⏻** button (<0.5S) to confirm your selected option.

Or highlight "EXIT" and press the **⏻** button (<0.5S) to return to the main menu, or highlight "BACK" and press (<0.5S) the **⏻** button (<0.5S) to return to the Settings interface.



1.7.1 "Display Setting"

Press the **+** or **-** button (<0.5S) and highlight Display Setting, and then briefly press the **⏻** button (<0.5S) to access the following selections.

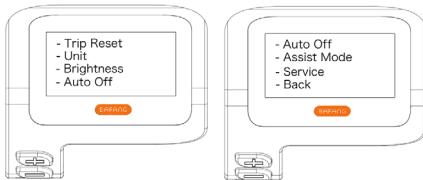

1.7.1.1 "TRIP Reset" Reset mileage

Press the **+** or **-** button (<0.5S) to highlight "Trip Reset" in the Display setting menu, and then press **⏻** button (<0.5S) to select. Then with the **+** or **-** button choose between "YES" or "NO". Once you have chosen your desired selection, press the **⏻** button (<0.5S) to save and exit to the "Display setting".



1.7.1.2 "Unit" Selections in km/Miles

Press the **+** or **-** button (<0.5S) to highlight "Unit" in the Display setting menu, and then press **↵** button (<0.5S) to select. Then with the **+** or **-** button choose between "Metric" (kilometer) or "Imperial" (Miles). Once you have chosen your desired selection, press the **↵** button (<0.5S) to save and exit to the "Display setting".

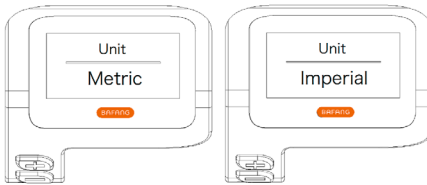

1.7.1.3 "Brightness" Display brightness

Press the **+** or **-** button (<0.5S) to highlight "Brightness" in the Display setting menu, and then press **↵** button (<0.5S) to select. Then with the **+** or **-** button choose between "100%" / "75%" / "50%" / "30%" / "10%". Once you have chosen your desired selection, press the **↵** button (<0.5S) to save and exit to the "Display setting".

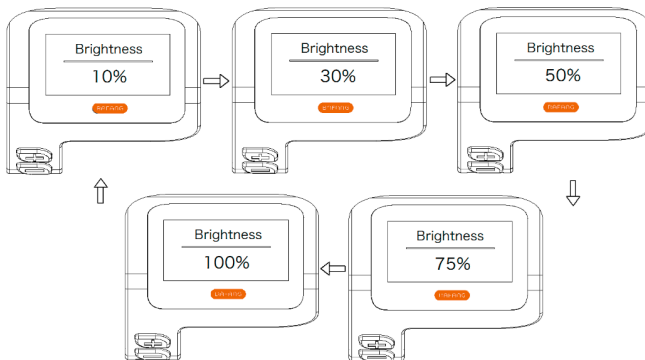

1.7.1.4 "Auto Off" Set Automatic system switch off time

Press the **+** or **-** button (<0.5S) to highlight "Auto Off" in the Display setting menu, and then press **↵** button (<0.5S) to select. Then with the **+** or **-** button choose between "OFF", "9"/"8"/"7"/"6"/"5"/"4"/"3"/"2"/"1", (The numbers are measured in minutes). Once you have chosen your desired selection, press the **↵** button (<0.5S) to save and exit to the "Display setting".

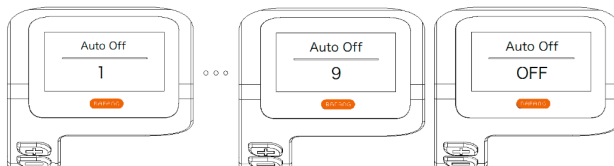

1.7.1.5 "Assist Mode" Set support level

Press the **+** or **-** button (<0.5S) to highlight "Max Pass" in the Display setting menu, and then press **⏻** button (<0.5S) to select. Then with the **+** or **-** button choose between "3/5/9" (the amount of support levels). Once you have chosen your desired selection, press the **⏻** button (<0.5S) to save and exit to the "Display setting".

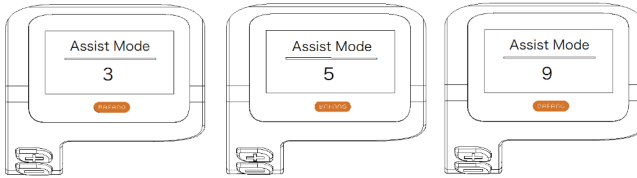

1.7.1.6 "Service" Switching the notification on and off

Press the **+** or **-** button (<0.5S) to highlight "Service" in the Display setting menu, and then press **⏻** button (<0.5S) to select. Then with the **+** or **-** button choose between "NO" or "YES". Once you have chosen your desired selection, press the **⏻** button (<0.5S) to save and exit to the "Display setting".

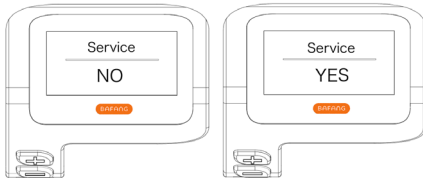

1.7.2 "Information"

Once the display is turned on, press and hold the **+** and **-** buttons (at the same time) to enter into the setting menu, press the **+** or **-** button (<0.5S) to select "Information", then press the **⏻** button (<0.5S) to confirm and enter into "Information".

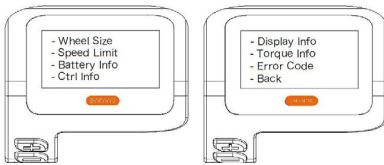

1.7.2.1 Wheel Size

Press the **+** or **-** button (<0.5S) to highlight "Wheel Size", then press the **⏻** button (<0.5S) to confirm and view the wheel size. To return, press the **⏻** button (<0.5S) to exit back to the "Information".

This information cannot be changed, this is only for information, about the pedelec.



1.7.2.2 Speed Limit

Press the **+** or **-** button (<0.5S) to highlight "Speed Limit", then press the **⏻** button (<0.5S) to confirm and view the speed limit. To return, press the **⏻** button (<0.5S) to exit back to the "Information".

This information cannot be changed, this is only for information, about the pedelec.

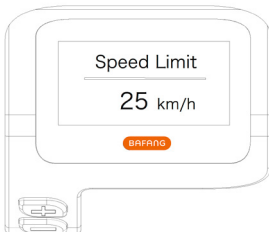

1.7.2.3 Battery Information

Press the **+** or **-** button (<0.5S) to highlight "Battery Info", then press the **⏻** button (<0.5S) to confirm. Now press the **+** or **-** button (<0.5S) to view the contents.

To return, press the **⏻** button (<0.5S) to exit back to the "Information".

Code	Code definition	unit	Code	Code definition	unit
Hardware ver	Hardware version		b10	Absolute SOC	%
Software ver	Software version		b11	Cycle	times
b01	Current temperature	°C	b12	Maximum not charging time	Hour
b04	Total voltage	mV	b13	Recently not charging time	Hour
b06	Average current	mA	d00	Number of battery cell	
b07	Remaining capacity	mAh	d01	Voltage of cell 1	mV
b08	Full charge capacity	mAh	d02	Voltage of cell 2	mV
b09	Relative SOC	%	dn	Voltage of cell n	mV

NOTE: If no data is detected, "--" is displayed.

1.7.2.4 Controller Information

Press the **+** or **-** button (<0.5S) to highlight "Ctrl Info", then press the **⏻** button (<0.5S) to confirm. Now press the **+** or **-** button (<0.5S) to view Hardware Version or Software Version.

To return, press the **⏻** button (<0.5S) to exit back to the "Information".

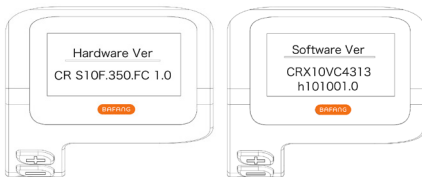

1.7.2.5 Display Information

Press the **+** or **-** button (<0.5S) to highlight "Display Info", then press the **⏻** button (<0.5S) to confirm. Now press the **+** or **-** button (<0.5S) to view Hardware Version or Software Version.
To return, press the **⏻** button (<0.5S) to exit back to the "Information".



1.7.2.6 Torque Information

Press the **+** or **-** button (<0.5S) to highlight "Torque Info", then press the **⏻** button (<0.5S) to confirm. Now press the **+** or **-** button (<0.5S) to view Hardware Version or Software Version.
To return, press the **⏻** button (<0.5S) to exit back to the "Information".

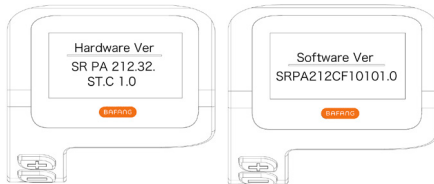

1.7.2.7 Error Code

Press the **+** or **-** button (<0.5S) to highlight "Error code", then press the **⏻** button (<0.5S) to confirm. Now press the **+** or **-** button (<0.5S) to view a list of error codes from the pedelec. It can show information for the last ten errors of the pedelec. The error code "00" means that there is no error.

To return, press the **⏻** button (<0.5S) to exit back to the "Information".



1.8 ERROR CODE DEFINITION



The HMI can show the faults of Pedelec. When a fault is detected, one of the following error codes will be indicated too.

Note: Please read carefully the description of the error code. When the error code appears, please first restart the system. If the problem is not eliminated, please contact your dealer or technical personnel.

Error	Declaration	Troubleshooting
04	The throttle is not back in its correct position.	Check the connector from the throttle is correctly connected. If this does not solve the problem, please change the throttle.
05	The throttle has fault.	<ol style="list-style-type: none">1. Check the connector and cable of the throttle are not damaged and correctly connected.2. Disconnect and reconnect the throttle, if still no function please change the throttle.
07	Overvoltage protection	<ol style="list-style-type: none">1. Remove and re-Insert the battery to see if it resolves the problem.2. Using the BESST tool update the controller.3. Change the battery to resolve the problem.
08	Error with the hall sensor signal inside the motor	<ol style="list-style-type: none">1. Check all connectors from the motor are correctly connected.2. If the problem still occurs, please change the motor.
09	Error with the Engine phase's	Please change the motor.
10	The temperature inside the engine has reached its maximum protection value	<ol style="list-style-type: none">1. Turn off the system and allow the Pedelec to cool down.2. If the problem still occurs, please change the motor.
11	The temperature sensor inside the motor has an error	Please change the motor.
12	Error with the current sensor in the controller	Please change the controller or contact your supplier.

Error	Declaration	Troubleshooting
13	Error with the temperature sensor inside of the battery	<ol style="list-style-type: none"> 1. Check all connectors from the battery are correctly connected to the motor. 2. If the problem still occurs, please change the Battery.
14	The protection temperature inside the controller has reached its maximum protection value	<ol style="list-style-type: none"> 1. Allow the pedelec to cool down and restart the system. 2. If the problem still occurs, please change the controller or contact your supplier.
15	Error with the temperature sensor inside the controller	<ol style="list-style-type: none"> 1. Allow the pedelec to cool down and restart the system. 2. If the problem still occurs, Please change the controller or contact your supplier.
21	Speed sensor Error	<ol style="list-style-type: none"> 1. Restart the system 2. Check that the magnet attached to the spoke is aligned with the speed sensor and that the distance is between 10 mm and 20 mm. 3. Check that the speed sensor connector is connected correctly. 4. Connect the pedelec to BESST, to see if there is a signal from the speed sensor. 5. Using the BESST Tool- update the controller to see if it resolves the problem. 6. Change the speed sensor to see if this eliminates the problem. If the problem still occurs, please change the controller or contact your supplier.
25	Torque signal Error	<ol style="list-style-type: none"> 1. Check that all connections are connected correctly. 2. Please connect the pedelec to the BESST system to see if torque can be read by the BESST tool. 3. Using the BESST Tool update the controller to see if it resolves the problem, if not please change the torque sensor or contact your supplier.

Error	Declaration	Troubleshooting
26	Speed signal of the torque sensor has an error	<ol style="list-style-type: none"> 1. Check that all connections are connected correctly. 2. Please connect the pedelec to the BESST system to see if speed signal can be read by the BESST tool. 3. Change the Display to see if the problem is solved. 4. Using the BESST Tool update the controller to see if it resolves the problem, if not please change the torque sensor or contact your supplier.
27	Overcurrent from controller	Using the BESST tool update the controller. If the problem still occurs, please change the controller or contact your supplier.
30	Communication problem	<ol style="list-style-type: none"> 1. Check all connections on the pedelec are correctly connected. 2. Using the BESST Tool run a diagnostics test, to see if it can pinpoint the problem. 3. Change the display to see if the problem is solved. 4. Change the EB-BUS cable to see if it resolves the problem. 5. Using the BESST tool, re-update the controller software. If the problem still occurs please change the controller or contact your supplier.
33	Brake signal has an error (If brake sensors are fitted)	<ol style="list-style-type: none"> 1. Check all connectors are correctly connected on the brakes. 2. Change the brakes to see if the problem is solved. <p>If problem continues Please change the controller or contact your supplier.</p>
35	Detection circuit for 15V has an error	Using the BESST tool update the controller to see if this resolves the problem. If not, please change the controller or contact your supplier.
36	Detection circuit on the keypad has an error	Using the BESST tool update the controller to see if this resolves the problem. If not, please change the controller or contact your supplier.

Error	Declaration	Troubleshooting
37	WDT circuit is faulty	Using the BESST tool update the controller to see if this resolves the problem. If not, please change the controller or contact your supplier.
41	Total voltage from the battery is too high	Please change the battery.
42	Total voltage from the battery is too low	Please Charge the battery. If the problem still occurs, please change the battery.
43	Total power from the battery cells is too high	Please change the battery.
44	Voltage of the single cell is too high	Please change the battery.
45	Temperature from the battery is too high	Please let the pedelec cool down. If problem still occurs, please change the battery.
46	The temperature of the battery is too low	Please bring the battery to room temperature. If the problem still occurs, please change the battery.
47	SOC of the battery is too high	Please change the battery.
48	SOC of the battery is too low	Please change the battery.
61	Switching detection defect	1. Check the gear shifter is not jammed. 2. Please change the gear shifter.
62	Electronic derailleur cannot release.	Please change the derailleur.
71	Electronic lock is jammed	1. Using the BESST tool update the Display to see if it resolves the problem. 2. Change the display if the problem still occurs, please change the electronic lock.
81	Bluetooth module has an error	Using the BESST tool, re-update the software onto the display to see if it resolves the problem. If not, Please change the display.

DP C240.CAN



CONTENT

2.1 Important Notice	22	2.6.4 Headlights / backlighting.....	26
2.2 Introduction of Display	22	2.6.5 Walk Assistance.....	26
2.3 Product Description	23	2.6.6 BOOST Function.....	27
2.3.1 Specifications.....	23	2.6.7 Battery Capacity Indication.....	27
2.3.2 Functions Overview.....	23	2.6.8 USB Charge Function.....	27
2.4 Display	24	2.7 Settings	28
2.5 Key Definition	24	2.8.1 "Display Setting".....	28
2.6 Normal Operation	25	2.8.2 "Information".....	30
2.6.1 Switching the System On/Off.....	25	2.8 Error Code Definition	32
2.6.2 Selection of Support Levels.....	25		
2.6.3 Selection Mode.....	25		

2.1 IMPORTANT NOTICE

- If the error information from the display cannot be corrected according to the instructions, please contact your retailer.
- The product is designed to be waterproof. It is highly recommended to avoid submerging the display under water.
- Do not clean the display with a steam jet, high-pressure cleaner or water hose.
- Please use this product with care.
- Do not use thinners or other solvents to clean the display. Such substances can damage the surfaces.
- Warranty is not included due to wear and normal use and aging.

2.2 INTRODUCTION OF DISPLAY

- Model: DP C240.CAN BUS
- The housing material is PC; the display windows is made of ACRYLIC material:
- The label marking is as follows:



- **Note:** Please keep the QR code label attached to the display cable. The information from the Label is used for a later possible software update.

2.3 PRODUCT DESCRIPTION

2.3.1 Specifications

- Operating temperature: -20°C~45°C
- Storage temperature: -20°C~50°C
- Waterproof: IP65
- Storage room Humidity: 30%-70% RH

2.3.2 Functional Overview

- Speed indication (including the real-time speed, max. speed and average speed)
- Unit switching between km and mile
- Battery capacity indicator
- Automatic sensors explanation of the lighting system
- Brightness setting for backlight
- Indication of performance support
- Kilometer stand (including single-trip distance, total distance and remaining distance)
- BOOST function (NOTE: it needs the controller has this function)
- Indication of power assistance level
- Time indication for ride
- Input power of motor indication
- Walk assistance
- Indication for error messages
- Indication for consumption of energy CALORIES (NOTE: If the controller has this function)
- Indication for the remaining distance. (NOTE: it needs the controller has this function)
- Button vibration setting
- USB charging (5V and 500mA)

2.4 DISPLAY

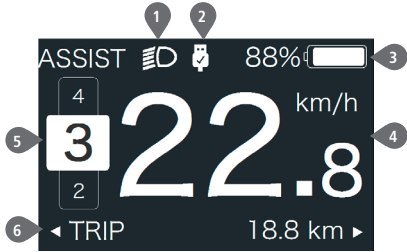

- 2 USB connection indication
- 3 Battery capacity indication
- 4 Speed display in real-time
- 5 Assistance level indication
- 6 Multiple data indication



- 1 Headlight indication

2.5 KEY DEFINITION



2.6 NORMAL OPERATION



2.6.1 Switching the System ON/OFF

Press  and hold (>2S) to power on the display, the HMI begin to show the boot up LOGO. Press  and hold (>2S) again can power off the HMI.

If the "automatic shutdown" time is set to 5 minutes (it can be set in function "Auto Off"), the HMI will be automatically turned off within this set time, When it is not operated.



2.6.2 Selection of Support Levels

When HMI power on, briefly press  or  to select the assistance level (the number of assistance level needs to be adapted to controller), The lowest level is Level 0, the highest Level is 5. On the default is Level 1, "0" means no power assistance. The interface is as following:

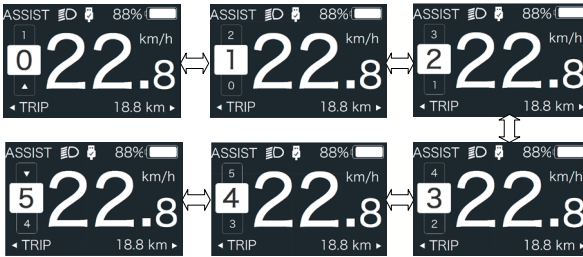

Note: if the controller has Boost function, can be selected this level with briefly press 2.

2.6.3 Selection Mode

Briefly press  button to view the different mode and information.

1. System with torque sensor, circularly show single trip distance (TRIP,km) → total distance (ODO,km) → maximum speed (MAX,km/h) → average speed (AVG,km/h) → remaining distance (RANGE,km) → energy consumption (CALORIES/CAL,KCal) → real-time output power (POWER,w) → riding time (TIME,min).
2. If system with a speed sensor, circularly show single trip distance (Trip,km) → total distance (ODO,km) → maximum speed (MAX,km/h) → average speed (AVG,km/h) → remaining distance (RANGE,km) → riding time (TIME,min).



2.6.4 Headlights / backlighting



Press and hold **+** (>2S) to turn on the backlight as well as headlight.

Press and hold **+** (>2S) again to turn off the backlight and the headlight. The brightness of backlight can be set in function "Brightness". (If the display is turned on in a dark environment, the display backlight/ headlight will be turned on automatically. If the display backlight/headlight are turned off manually, they also need to be turned on manually afterwards)





2.6.5 Walk Assistance

The Walk assistance can only be activated with a standing pedelec.

Activation: briefly press **+** button until this symbol  appears. Next hold down the **+** button whilst the  symbol is displayed. Now the Walk assistance will activate. The symbol will flash and the pedelec moves approx. 6 km/h. After releasing the **+** button the motor stops automatically and if no any operations within 5s will automatically return to 0 level (as following).



2.6.6 BOOST Function

In riding, when speed is arrived 25km/h, can select in BOOST level, at this point press  button and hold (>2S), then the Pedelec enters in BOOST function. The indicator  on display will flash and the motor output with max. power. (BOOST function as following). If release the button or do any other operation will stop BOOST.

NOTE: If the speed is not arrived 25km/h, this function can not be implemented and press  button and hold (>2S) the HMI can powered off.



2.6.7 Battery Capacity Indication

The percentage of current battery capacity and total capacity is displayed from 100% to 0% according to the actual capacity (as shown in the figure below)

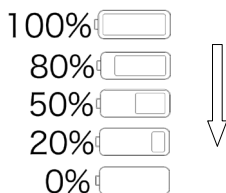

2.6.8 USB Charge Function

When the HMI is off, insert the USB device to the USB charging port on the HMI, and then turn on HMI to charge. When the HMI is on, can direct charge for USB device. the maximum charging voltage is 5V and the maximum charging current is 500mA.

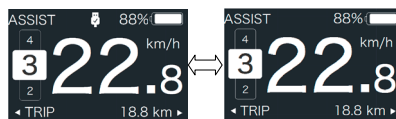

2.7 SETTINGS

After the HMI powered on, press and hold **+** and **-** button (at the same time) to enter into the setting interface. Briefly press (<0.5S) **+** or **-** button to select "Setting", "Information" or "Exit", then briefly press (<0.5S) **⏻** button to confirm.

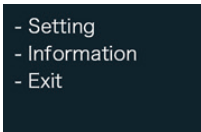

You can press and hold **+** and **-** button at any time, to return to the main screen.

2.7.1 "Setting" interface

After the HMI powered on, press and hold **+** and **-** button to enter into the setting interface. Briefly press (<0.5S) **+** or **-** to select "Setting" and then briefly press **⏻** (<0.5S) to confirm.

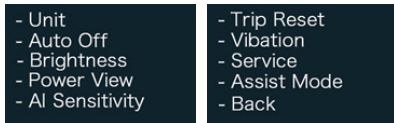

2.7.1.1 "Unit" Selections in km/Miles

Briefly press **+** or **-** to select "Unit", and briefly press **⏻** to enter into the item. Then choose between "Metric" (kilometer) or "Imperial" (Miles) with the **+** or **-** button. Once you have chosen your desired selection, press the **⏻** button (<0.5S) to save and exit back to the "Setting" interface.



2.7.1.2 "Auto Off" Set automatic Off time

Briefly press **+** or **-** to select "Auto Off", and briefly press **⏻** to enter into the item. Then select the automatic Off time as "OFF" / "9" / "8" / "7" / "6" / "5" / "4" / "3" / "2" / "1" with the **+** or **-** button. Once you have chosen your desired selection, press the **⏻** button (<0.5S) to save and exit back to the "Setting" interface.

Notice: "OFF" means this function is off, the unit is minute.

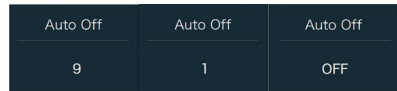

2.7.1.3 "Brightness" Display brightness

Briefly press **+** or **-** to select "Brightness", and briefly press **⏻** to enter into the item. Then select the percentage as "100%" / "75%" / "50%" / "30%" / "10%" with the **+** or **-** button. Once you have chosen your desired selection, press the **⏻** button (<0.5S) to save and exit back to the "Setting" interface.

Notice: "10%" is the weakest brightness and 100%" is the strongest brightness.

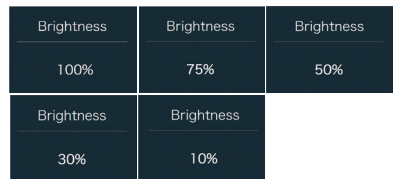





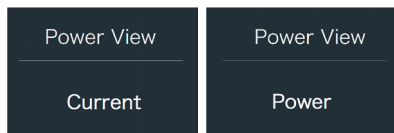

2.7.1.4 "Power View" Set output display mode

Briefly press **+** or **-** to select "Power View", and briefly press **⏻** to enter into the item. Then select the output display mode as "Power" / "Current" with the **+** or **-** button.

Once you have chosen your desired selection, press the  button (<0.5S) to save and exit back to the "Setting" interface.









2.7.1.5 "AL Sensitivity" Set light sensitivity

Briefly press  or  to select "AL Sensitivity", and briefly press  to enter into the item. Then select the level of the light sensitivity as "0"/"1"/"2"/"3"/"4"/"5" with the  or  button. Once you have chosen your desired selection, press the  button (<0.5S) to save and exit back to the "Setting" interface.

Notice: "0" means light sensor is off. Level 1 is the weakest sensitivity and level 5 is the strongest sensitivity.







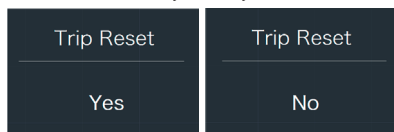

2.7.1.6 "TRIP Reset" Set reset function for single-trip

Briefly press  or  to select "AL Sensitivity", and briefly press  to enter into the item. Then select "NO"/"YES" ("YES" - to clear, "NO"-no operation) with the  or  button. Once you have chosen your desired selection, press the  button (<0.5S) to save and exit back to the "Setting" interface.

Notice: The riding time(TIME), average speed (AVG) and maximum speed (MAXS) will be reset simultaneously when you reset TRIP.







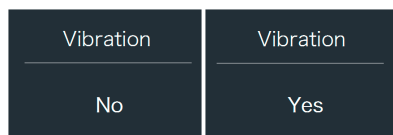

2.7.1.7 "Vibration" Set the button vibration

Briefly press  or  to select "Vibration", and briefly press  to enter into the item. Then select "NO"/"YES" ("YES" means vibration button is on; "NO" means vibration button is off) with the  or  button. Once you have chosen your desired selection, press the  button (<0.5S) to save and exit back to the "Setting" interface.







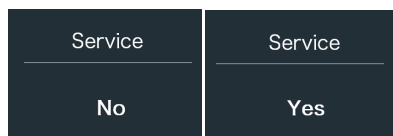

2.7.1.8 "Service" Turn on/off the Service indication

Briefly press  or  to select "Service", and briefly press  to enter into the item. Then select "NO"/"YES" ("YES" means Service indication is on; "NO" means Service indication is off) with the  or  button. Once you have chosen your desired selection, press the  button (<0.5S) to save and exit back to the "Setting" interface.



2.7.1.9 "Assist Mode" Set the assist level

Briefly press  or  to select "Assist Mode", and briefly press  to enter into the item. Then select the assistance level as "3"/"5"/"9" with the  or  button. Once you have chosen your desired selection, press the  button (<0.5S) to save and exit back to the "Setting" interface.

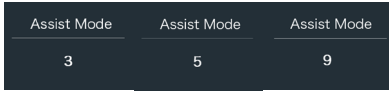

2.7.2 "Information"

After the HMI powered on, press and hold **+** and **-** to enter into the setting function. Briefly press (<0.5S) **+** or **-** to select "Information" and then briefly press **⏻** (<0.5S) to confirm.

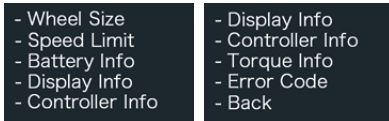

Note: All information here cannot be changed, it is to be viewed only.

2.7.2.1 "Wheel Size"

Briefly press **+** or **-** to select "Wheel Size", and then briefly press **⏻** to view the wheel size default.

Press the **⏻** button (<0.5S) to exit back to the "Information" interface.

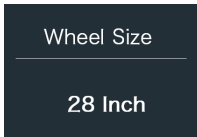

2.7.2.2 "Speed Limit"

Briefly press **+** or **-** to select "Speed Limit", and then briefly press **⏻** to view the speed limit default.

Press the **⏻** button (<0.5S) to exit back to the "Information" interface.

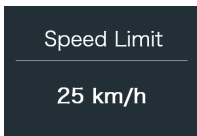

2.7.2.3 "Battery Info"

Briefly press **+** or **-** to select "Battery Info", and briefly press **⏻** to enter, then briefly press **+** or **-** to view the battery data (b01 → b04 → b06 → b07 → b08 → b09 → b10 → b11 → b12 → b13 → d00 → d01 → d02 → ... → dn → Hardware Ver → Software Ver).

Press the **⏻** button (<0.5S) to exit back to the "Information" interface.

Notice: If the battery doesn't have communication function, you won't see any data from battery.

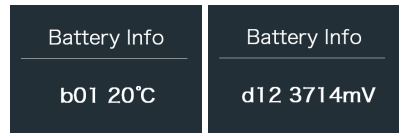

View the battery information



View the hardware and software version of battery

Code	Code Definition	Unit
b01	Current temperature	°C
b04	Battery voltage	mV
b06	Current	mA
b07	Remaining battery capacity	mAh
b08	Battery capacity of Full charged	mAh
b09	Relative SOC	%
b10	Absolute SOC	%

Code	Code Definition	Unit
b11	Cycle Times	times
b12	Max Uncharge Time	Hour
b13	Last Uncharge Time	Hour
d00	The number of cell	
d01	Voltage Cell 1	mV
d02	Voltage Cell 2	mV
dn	Voltage Cell n	mV
Hardware Ver	Battery Hardware Version	
Software Ver	Battery Software Version	

NOTE: If no data is detected, "--" will be displayed.

2.7.2.4 "Display Info"

Briefly press **+** or **-** to select "Display Info", and briefly press **⏻** to enter, briefly press **+** or **-** to view "Hardware Ver" or "Software Ver".

Press the **⏻** button (<0.5S) to exit back to the "Information" interface.

Hardware Ver	Software Ver
DP C240.C 2.0	DPC240CI1020 2.0

2.7.2.5 "Ctrl Info"

Briefly press **+** or **-** to select "Ctrl Info", and briefly press **⏻** to enter, briefly press **+** or **-** to view "Hardware Ver" or "Software Ver".

Press the **⏻** button (<0.5S) to exit back to the "Information" interface.

HardWare Ver	SoftWare Ver
X10B.350.FC 1.0	CRX10BC4313 E101003.0

2.7.2.6 "Torque Info"

Briefly press **+** or **-** to select "Torque Info", and briefly press **⏻** to enter, briefly press **+** or **-** to view "Hardware Ver" or "Software Ver".

Press the **⏻** button (<0.5S) to exit back to the "Information" interface.

HardWare Ver	SoftWare Ver
SR PA212.32. ST.C 1.0	SRPA212CF1 0101.0

NOTE: If your Pedelec doesn't have torque sensor, "--" will be displayed.

2.7.2.7 "Error Code"

Briefly press **+** or **-** to select "Error Code", and then briefly press **⏻** to enter, briefly press **+** or **-** to view message of error for last ten times by "E-Code00" to "E-Code09". Press the **⏻** button (<0.5S) to exit back to the "Information" interface.

NOTE: 00 means no error exist.

Error Code	Error
E-Code00 30	30

2.8 ERROR CODE DEFINITION



The HMI can show the faults of Pedelec. When a fault is detected, one of the following error codes will be indicated too.

Note: Please read carefully the description of the error code. When the error code appears, please first restart the system. If the problem is not eliminated, please contact your dealer or technical personnel.

Error	Declaration	Troubleshooting
04	The throttle is not back in its correct position.	Check the connector from the throttle is correctly connected. If this does not solve the problem, please change the throttle.
05	The throttle has fault.	<ol style="list-style-type: none">1. Check the connector and cable of the throttle are not damaged and correctly connected.2. Disconnect and reconnect the throttle, if still no function please change the throttle.
07	Overvoltage protection	<ol style="list-style-type: none">1. Remove and re-Insert the battery to see if it resolves the problem.2. Using the BESST tool update the controller.3. Change the battery to resolve the problem.
08	Error with the hall sensor signal inside the motor	<ol style="list-style-type: none">1. Check all connectors from the motor are correctly connected.2. If the problem still occurs, please change the motor.
09	Error with the Engine phase's	Please change the motor.
10	The temperature inside the engine has reached its maximum protection value	<ol style="list-style-type: none">1. Turn off the system and allow the Pedelec to cool down.2. If the problem still occurs, please change the motor.
11	The temperature sensor inside the motor has an error	Please change the motor.
12	Error with the current sensor in the controller	Please change the controller or contact your supplier.

Error	Declaration	Troubleshooting
13	Error with the temperature sensor inside of the battery	<ol style="list-style-type: none"> 1. Check all connectors from the battery are correctly connected to the motor. 2. If the problem still occurs, please change the Battery.
14	The protection temperature inside the controller has reached its maximum protection value	<ol style="list-style-type: none"> 1. Allow the pedelec to cool down and restart the system. 2. If the problem still occurs, please change the controller or contact your supplier.
15	Error with the temperature sensor inside the controller	<ol style="list-style-type: none"> 1. Allow the pedelec to cool down and restart the system. 2. If the problem still occurs, Please change the controller or contact your supplier.
21	Speed sensor Error	<ol style="list-style-type: none"> 1. Restart the system 2. Check that the magnet attached to the spoke is aligned with the speed sensor and that the distance is between 10 mm and 20 mm. 3. Check that the speed sensor connector is connected correctly. 4. Connect the pedelec to BESST, to see if there is a signal from the speed sensor. 5. Using the BESST Tool- update the controller to see if it resolves the problem. 6. Change the speed sensor to see if this eliminates the problem. If the problem still occurs, please change the controller or contact your supplier.
25	Torque signal Error	<ol style="list-style-type: none"> 1. Check that all connections are connected correctly. 2. Please connect the pedelec to the BESST system to see if torque can be read by the BESST tool. 3. Using the BESST Tool update the controller to see if it resolves the problem, if not please change the torque sensor or contact your supplier.

Error	Declaration	Troubleshooting
26	Speed signal of the torque sensor has an error	<ol style="list-style-type: none"> 1. Check that all connections are connected correctly. 2. Please connect the pedelec to the BESST system to see if speed signal can be read by the BESST tool. 3. Change the Display to see if the problem is solved. 4. Using the BESST Tool update the controller to see if it resolves the problem, if not please change the torque sensor or contact your supplier.
27	Overcurrent from controller	Using the BESST tool update the controller. If the problem still occurs, please change the controller or contact your supplier.
30	Communication problem	<ol style="list-style-type: none"> 1. Check all connections on the pedelec are correctly connected. 2. Using the BESST Tool run a diagnostics test, to see if it can pinpoint the problem. 3. Change the display to see if the problem is solved. 4. Change the EB-BUS cable to see if it resolves the problem. 5. Using the BESST tool, re-update the controller software. If the problem still occurs please change the controller or contact your supplier.
33	Brake signal has an error (If brake sensors are fitted)	<ol style="list-style-type: none"> 1. Check all connectors are correctly connected on the brakes. 2. Change the brakes to see if the problem is solved. <p>If problem continues Please change the controller or contact your supplier.</p>
35	Detection circuit for 15V has an error	Using the BESST tool update the controller to see if this resolves the problem. If not, please change the controller or contact your supplier.
36	Detection circuit on the keypad has an error	Using the BESST tool update the controller to see if this resolves the problem. If not, please change the controller or contact your supplier.

Error	Declaration	Troubleshooting
37	WDT circuit is faulty	Using the BESST tool update the controller to see if this resolves the problem. If not, please change the controller or contact your supplier.
41	Total voltage from the battery is too high	Please change the battery.
42	Total voltage from the battery is too low	Please Charge the battery. If the problem still occurs, please change the battery.
43	Total power from the battery cells is too high	Please change the battery.
44	Voltage of the single cell is too high	Please change the battery.
45	Temperature from the battery is too high	Please let the pedelec cool down. If problem still occurs, please change the battery.
46	The temperature of the battery is too low	Please bring the battery to room temperature. If the problem still occurs, please change the battery.
47	SOC of the battery is too high	Please change the battery.
48	SOC of the battery is too low	Please change the battery.
61	Switching detection defect	1. Check the gear shifter is not jammed. 2. Please change the gear shifter.
62	Electronic derailleur cannot release.	Please change the derailleur.
71	Electronic lock is jammed	1. Using the BESST tool update the Display to see if it resolves the problem. 2. Change the display if the problem still occurs, please change the electronic lock.
81	Bluetooth module has an error	Using the BESST tool, re-update the software onto the display to see if it resolves the problem. If not, Please change the display.

H300 (RM G010.250.D)



CONTENT

3.1 Introduction	38
3.2 Specifications.....	39
3.2.1 Surface.....	39
3.2.2 Storage Information.....	39
3.3 Maintenance.....	39

3.1 INTRODUCTION



- **Product Model**

RM G010.250.D

- **Scope**



Applies only to electrically powered pedelecs developed or licensed by Bafang. It is suitable for city and trekking bikes, which have been developed for road use. The engine is not suitable for sport competitions.

- **Identification**

The following graphic, is the identification numbers of the product, which are shown on the housing:

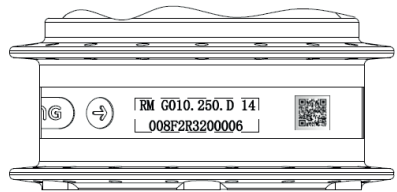

Note: Content in the label is important information about this product. Please do not remove the information from the motor.

3.2 SPECIFICATIONS

Motor model: RM G010.250.D

Rated power (W)	250
Rated voltage (V)	36 / 43
Waterproof	IP65
Certification	CE-EMC
Outdoor Temperatures	-20 C ~45 C

3.2.1 Surface

Shockproof black and silver coating

3.2.2 Storage Information

The pedelec should be stored in a ventilated dry room. Avoid storing the pedelec near strong magnetic objects.

3.3 MAINTENANCE

- Maintenance must be carried out by authorized personnel with the correct equipment.
- Do not disassemble the motor.
- Do not use thinners or other solvents to clean the components. Such substances can damage the surfaces.
- Avoid water submerging, to keep the components protected.
- Avoid using high-pressure cleaning jets.
- For prolonged storage, turn off the battery and avoid storing near heat sources.

H400B (RM G020.250/350.DC)



CONTENT

4.1 Introduction	42
4.2 Specifications.....	43
4.2.1 Surface.....	43
4.2.2 Storage Information.....	43
4.3 Maintenance.....	43

4.1 INTRODUCTION



- **Product Model**

RM G020.250.DC

RM G020.350.DC

- **Scope**

i Applies only to electrically powered pedelecs developed or licensed by Bafang. It is suitable for city and trekking bikes, which have been developed for road use. The engine is not suitable for sport competitions.

- **Identification**

The following graphic, is the identification numbers of the product, which are shown on the housing:

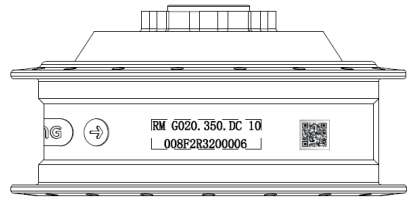

Note: Content in the label is important information about this product. Please do not remove the information from the motor.

4.2 SPECIFICATIONS

Motor model: RM G020.250.DC / RM G020.350.DC

Rated power (W)	250 / 350
Rated voltage (V)	36 / 43 / 48
Waterproof	IP65
Certification	CE-EMC
Outdoor Temperatures	-20 C ~45 C

4.2.1 Surface

Shockproof black and silver coating

4.2.2 Storage Information

The pedelec should be stored in a ventilated dry room. Avoid storing the pedelec near strong magnetic objects.

4.3 MAINTENANCE

- Maintenance must be carried out by authorized personnel with the correct equipment.
- Do not disassemble the motor.
- Do not use thinners or other solvents to clean the components. Such substances can damage the surfaces.
- Avoid water submerging, to keep the components protected.
- Avoid using high-pressure cleaning jets.
- For prolonged storage, turn off the battery and avoid storing near heat sources.

RM G370.250.DC



CONTENT

5.1 Introduction	46
5.2 Specifications	47
5.2.1 Surface.....	47
5.2.2 Storage Information.....	47
5.3 Maintenance	47

5.1 INTRODUCTION



- **Product Model**
RM G370.250.DC

- **Scope**

i Applies only to electrically powered pedelecs developed or licensed by Bafang. It is suitable for city, trekking and road bikes, which have been developed for road use. The engine is not suitable for sport competitions.

- **Identification**

The following graphic, is the identification numbers of the product, which are shown on the housing:

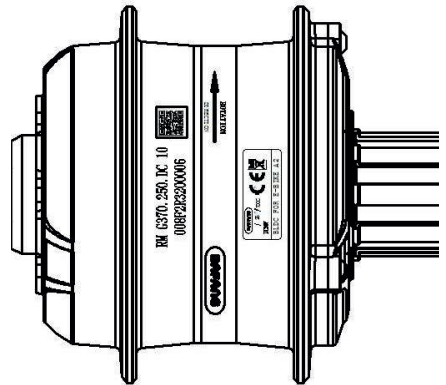

Note: Content in the label is important information about this product. Please do not remove the information from the motor.

5.2 SPECIFICATIONS

Motor model: RM G370.250.DC

Rated power (W)	250
Rated voltage (V)	36 / 43
Waterproof	IP65
Certification	CE
Outdoor Temperatures	-20 °C~45 °C

5.2.1 Surface

Shockproof black coating

5.2.2 Storage Information

The pedelec should be stored in a ventilated dry room. Avoid storing the pedelec near strong magnetic objects.

5.3 MAINTENANCE

- Maintenance must be carried out by authorized personnel with the correct equipment.
- Do not disassemble the motor.
- Do not use thinners or other solvents to clean the components. Such substances can damage the surfaces.
- Avoid water submerging, to keep the components protected.
- Avoid using high-pressure cleaning jets.
- For prolonged storage, turn off the battery and avoid storing near heat sources.